

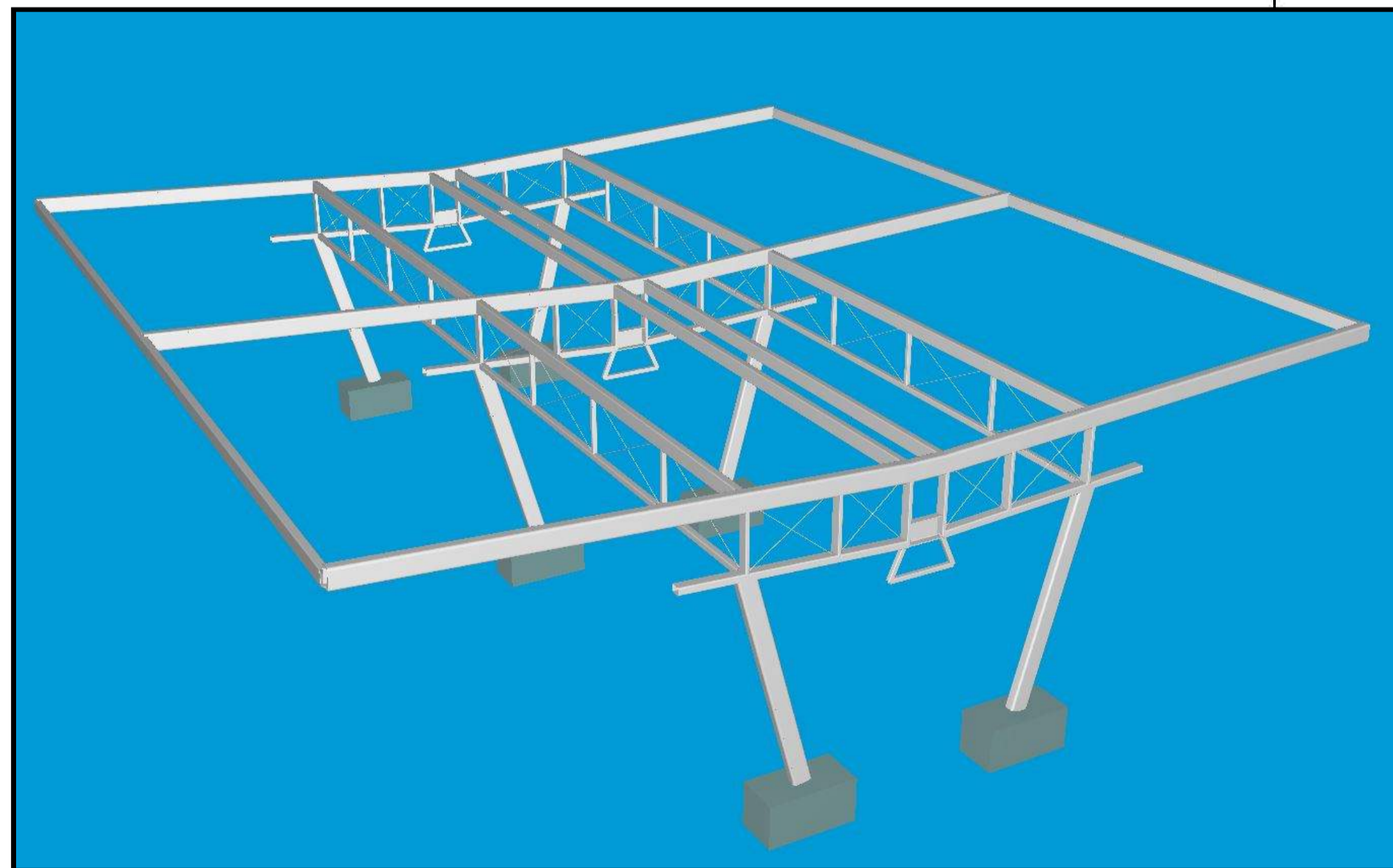

SURROUNDING PUBLIC SPACE STRUCTURES

PROPOSE INSULATED PANEL
150mm THICK OVER
STRUCTURAL STEEL
GALVANISED FRAME.

DH-50 AIRFRAME SHAPE COULD
BE PAINTED IN ACCENT
COLOURS OVER GALV

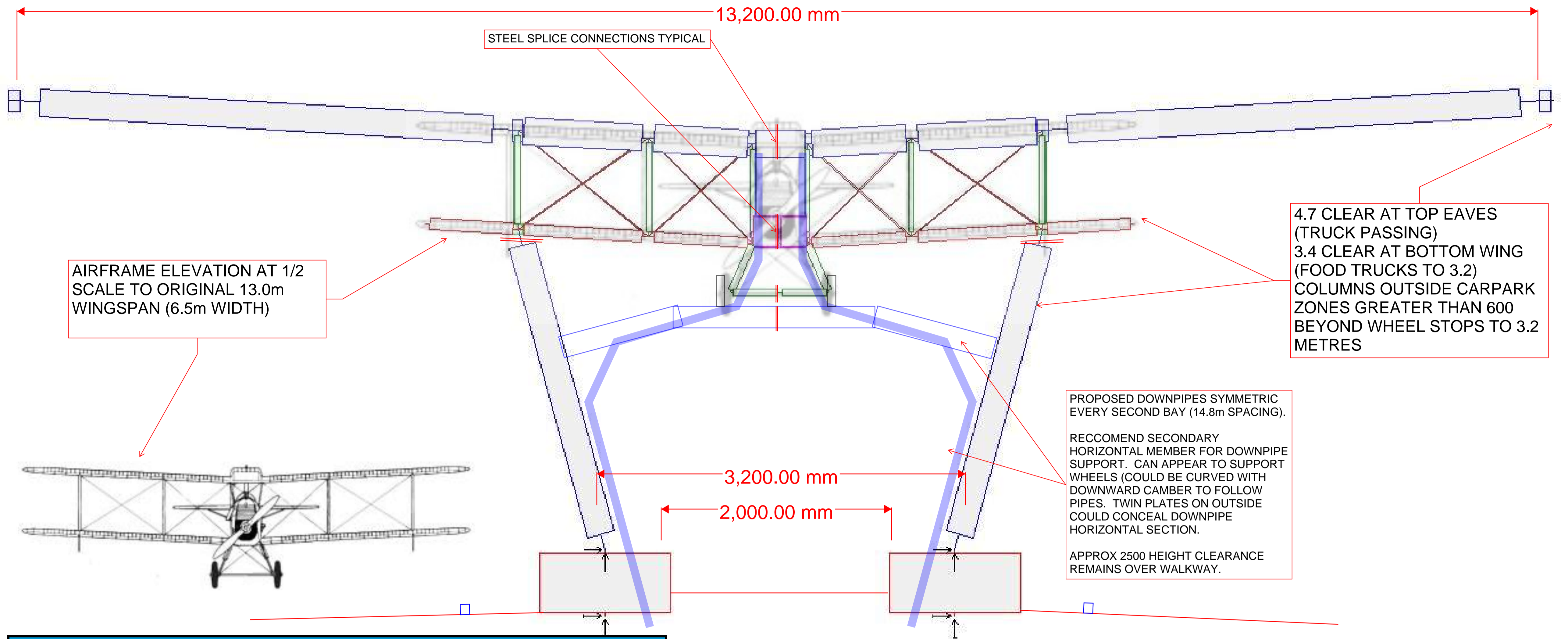

- AWNING INSPIRED BY RFDS ORIGINS:**
- DH-50 AT 1/2 SCALE ELEVATION INTEGRATED TO THE STRUCTURAL FRAME
 - ROOF PITCH 3.1 DEGREES MATCHING WING PITCH
 - BOX GUTTER TO CENTRE LINE
 - WHEEL FRAMES POTENTIAL FOR LIGHTING OR SPEAKER MOUNTS
 - LATERAL BRACING USING STAINLESS STEEL WIRES IN THE STYLE OF THE DH-50



"Qantas supplied the first aircraft to the fledgling organisation, VH-UER a De Havilland DH.50, dubbed "Victory". On 17 May 1928"



1:1	0	10m at full size	20cm
-----	---	------------------	------

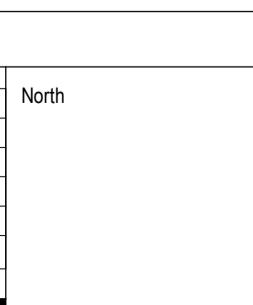

Client



1. This is the property of the engineer and may not be used, copied or reproduced wholly or in part without the express permission of the engineer.
2. Figured dimension take precedence over scale.
3. Verify all dimensions on site.

Project
SCARR STREET UPGRADE
CLONCURRY

Drawing Title DH-50 STREET CARPARK AWNING			
Drawn SM	Date 29-02-2024	Scale @ 1:20 @ A1	
Checked	Project No. PTP-13741	Dwg No. SK-DH50-01	Issue

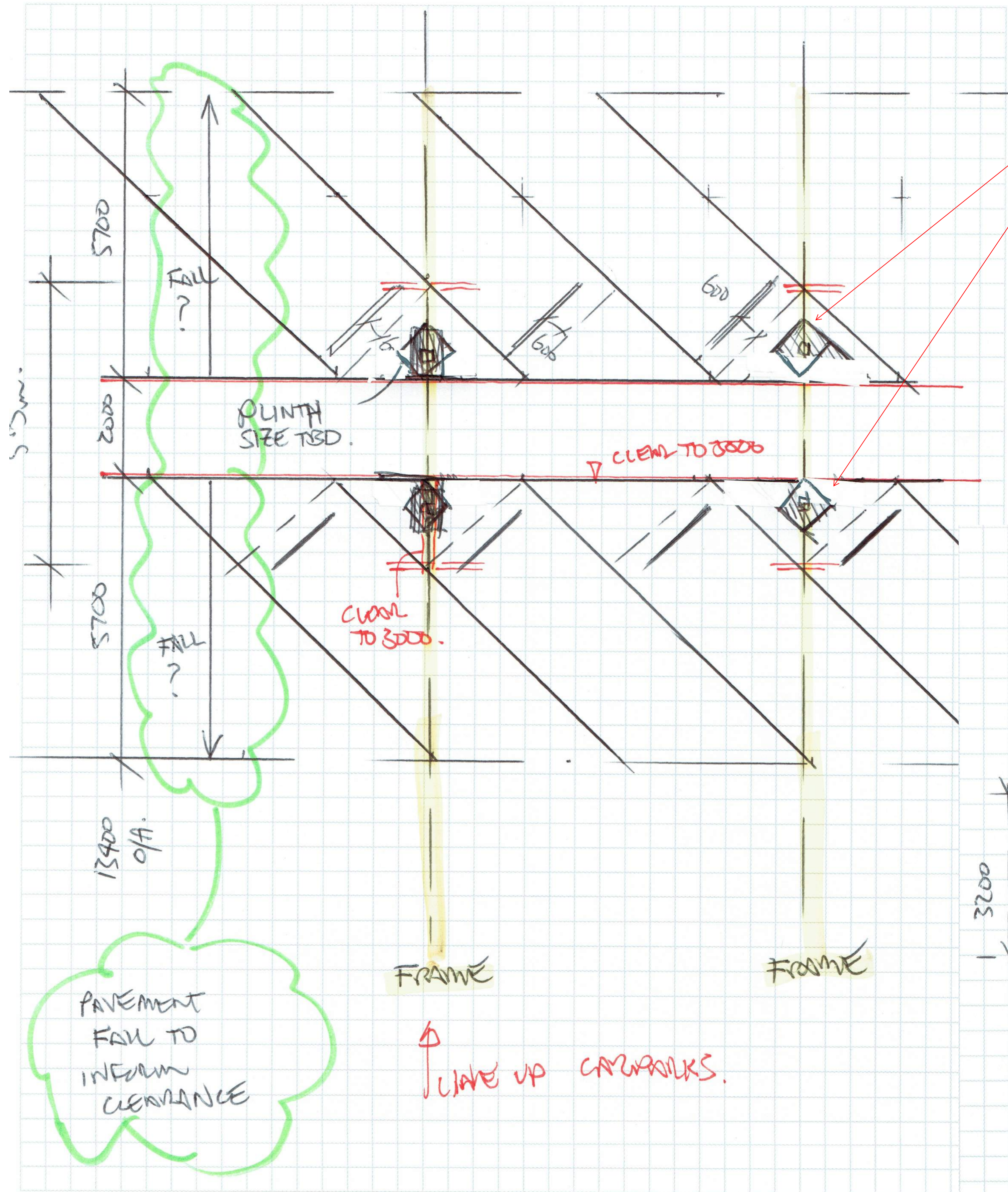

REQUESTED CARPARK ALIGNMENT ALONG CENTRE:
 OPPOSITE CARPARKS ALIGNED TO ALLOW FOR STRUCTURES TO BE IN MAXIMUM SIZE 45 DEGREE INTERSECTION ZONE TO AVOID VEHICLE IMPACTS

HAND SKETCH CONCEPT ELEVATION:
 PITCH TO MATCH DH-50 HEIGHTS TO CLEAR SEMI-TRAILERS AND ROAD TRAINS AT EAVES, FOOD TRUCKS AT CAR PARK EDGE LIMITS.

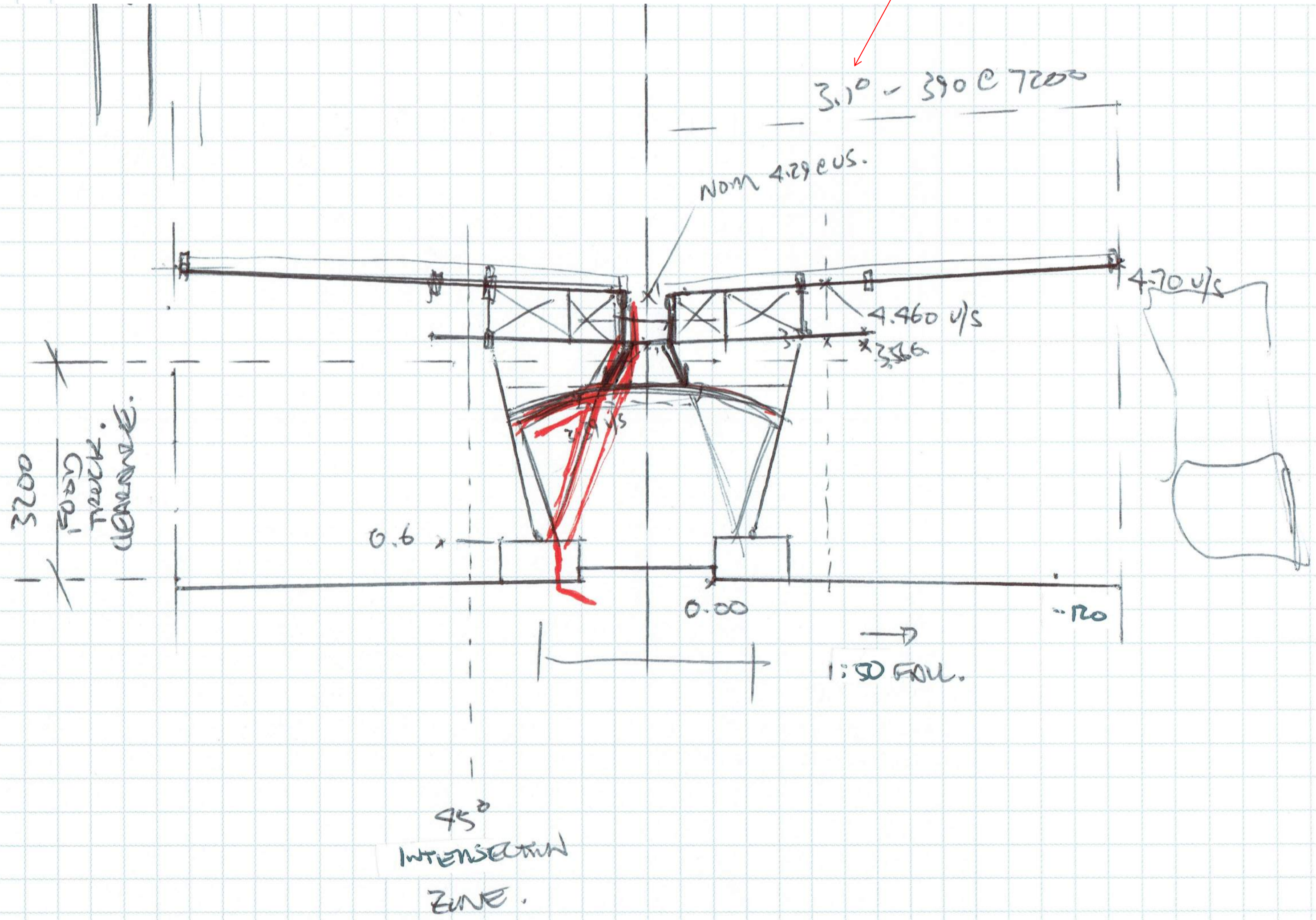

North	
1:1	1:20
1:50	1:100
1:200	1:500
1:1000	1:2000

Client



- This is the property of the engineer and may not be used, copied or reproduced wholly or in part without the express permission of the engineer.
- Figured dimension take precedence over scale.
- Verify all dimensions on site.

Project
 SCARR STREET UPGRADE
 CLONCURRY

Drawing Title
 CARPARK SETOUT REQUIREMENTS

Drawn SM	Date 29-02-2024	Scale @ 1:20 @ A1
Checked	Project No. PTP-13741	Dwg No. SK-DH50-02
		Issue



4200 approx

3100 approx

North

Client



1. This is the property of the engineer and may not be used, copied or reproduced wholly or in part without the express permission of the engineer.
2. Figured dimension take precedence over scale.
3. Verify all dimensions on site.

Project
**SCARR STREET UPGRADE
 CLONCURRY**

Drawing Title EXISTING STRUCTURE - RAMSAY ST			
Drawn SM	Date 29-02-2024	Scale @ 1:20 @ A1	
Checked	Project No. PTP-13741	Dwg No. SK-DH50-03	Issue